

R-622HD

Rotary idrauliche
Hydraulic rotary rigs



SOILMEC 

R-622HD

Le attrezzature di perforazione **serie R-622 HD** su carro base **SOILMEC** sono progettate per eseguire i seguenti lavori:

- ▶ pali trivellati a secco o con fluidi di perforazione;
- ▶ pali trivellati con l'infissione ed estrazione di tubi di rivestimento con o senza morsa;
- ▶ pali ad elica continua;
- ▶ pali battuti tipo vibrotrevi;
- ▶ diaframmi con benna SOILMEC BH-8, BH-10 e BH-12;
- ▶ pali a circolazione inversa;
- ▶ pali secanti con doppia testa.

Le caratteristiche qualificanti della **R-622HD** sono:

- ▶ classe macchina 65 t.;
- ▶ completamente automontante;
- ▶ possibilità di intubaggio con testa di rotazione;
- ▶ moderna strumentazione;
- ▶ affidabilità e sicurezza.

The **R-622HD** drilling rig mounted on **SOILMEC** base carrier has been specially designed to perform the following applications:

- ▶ bored piles with or without drilling fluid;
- ▶ casing with rotary head or by the use of an oscillator;
- ▶ continuous flight auger piles (C.F.A);
- ▶ cast-in-situ installing the casing by means of vibrating clamp (Vibrotrevi system);
- ▶ diaphragm wall with SOILMEC grabs BH-8, BH-10 and BH-12;
- ▶ bored piles by reverse circulation;
- ▶ secant piles with double head (C.S.P.).

The main features of **R-622HD** are the followings:

- ▶ a 65 ton class machine;
- ▶ completely self-erecting;
- ▶ casing can be installed by means of a rotary head;
- ▶ sophisticated instrumentation;
- ▶ reliability and safety.

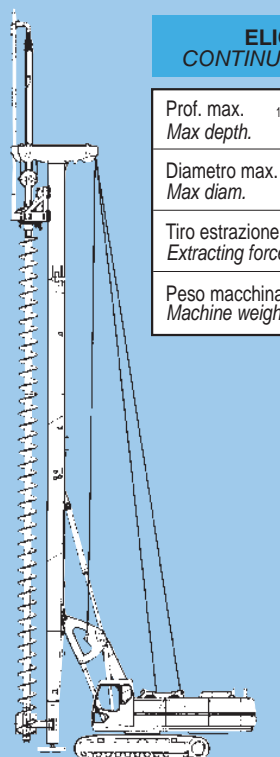
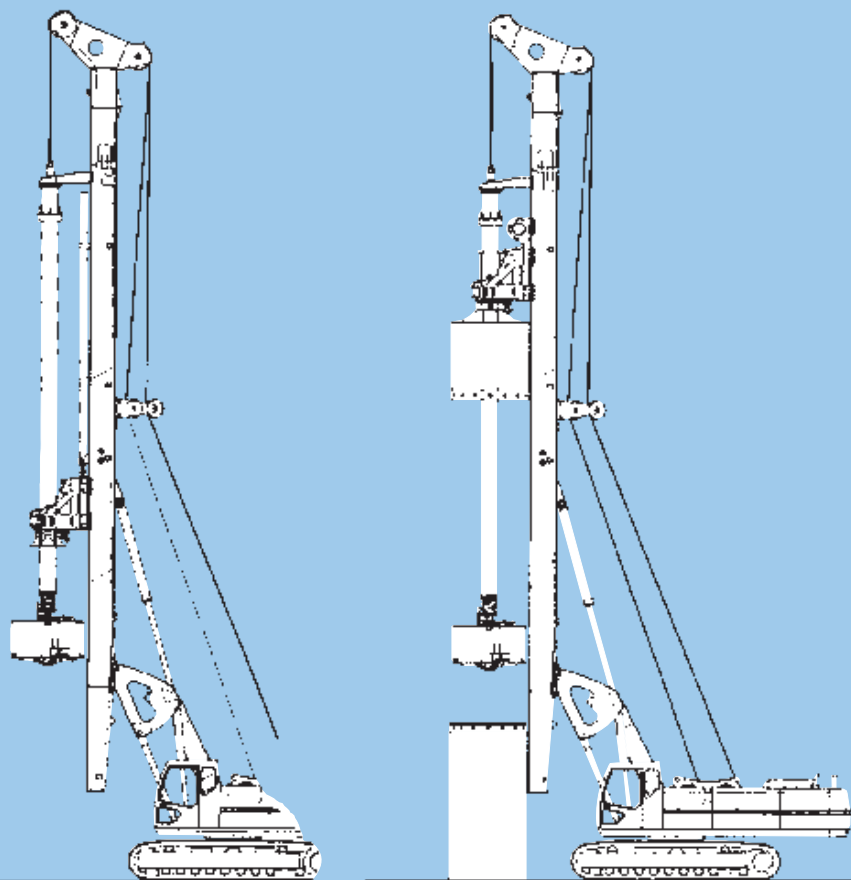

ELICA CONTINUA CONTINUOUS FLIGHT AUGER

Prof. max. Max depth.	19,5 + 6 m estensione 19,5 + 6 m extension	m	25,5
Diametro max. Max diam.		mm	1200
Tiro estrazione Extracting force		kN	732
Peso macchina Machine weight		t	65÷70

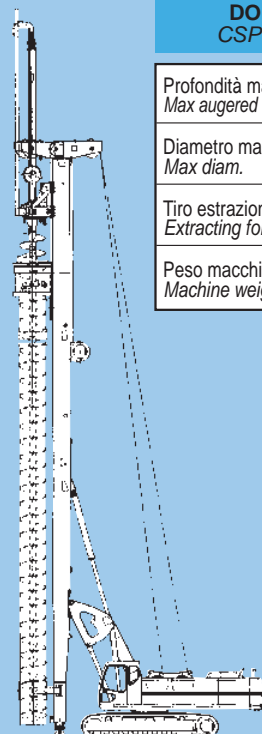

DOPPIA TESTA / CSP CSP / DOUBLE ROTARY

Profondità max. (intubato) Max augered (cased) depth.	m	21,5 (15)
Diametro max. Max diam.	mm	1000
Tiro estrazione Extracting force	kN	732
Peso macchina Machine weight	t	70÷75

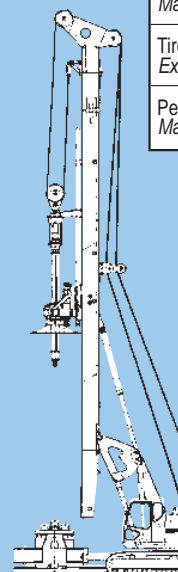



PALO GRANDE DIAMETRO / LARGE DIAMETER BORED PILE

Diametro max foro <i>Max. pile diameter</i>	mm	2500 (2000 intubato/cased)
Profondità max foro <i>Max. pile depth</i>	m	77
Coppia massima nominale (35 MPa) <i>Max nominal torque (35 MPa)</i>	kNm	201
Velocità massima perforazione <i>Max drilling speed</i>	rpm	34
Velocità di scarico <i>Spin-off</i>	rpm	144
Tiro nominale argano principale <i>Main winch nominal line pull (ISO M5 - L2 - T5)</i>	kN	200
Tiro nominale argano ausiliare <i>Service winch nominal line pull (ISO M5 - L2 - T5)</i>	kN	100 ÷ 140
Motore* <i>Engine</i>	Tipo <i>Type</i>	Deutz BF6M1015 Deutz BF6M1015C
Potenza <i>Power</i>	kW (BHP)	240 (326) @ 2100 rpm 300 (408) @ 2100 rpm
Sistema tiro/spinta <i>Crowd system</i>	kN	264 / 201
Peso macchina <i>Operating weight</i>	t	65 ÷ 70

PESI / WEIGHTS

Peso con torre da 13,5 m e prolunga da 1,5 m <i>Weight with 13,5 m mast section and 1,5 m extension only</i>	46.800 kg
Peso senza aste e zavorra <i>Weight without kelly and counterweight</i>	54.500 kg

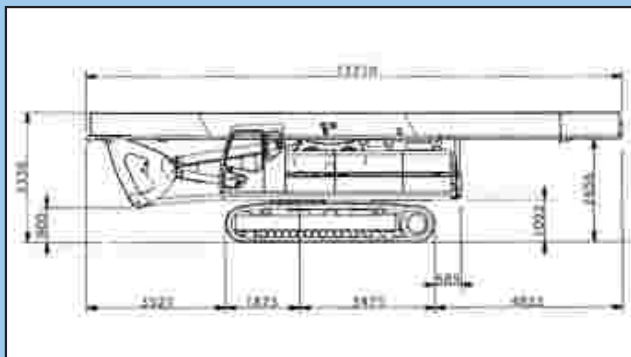

SISTEMA IDRAULICO / Hydraulic System

Pompa doppia principale / Main twin pumps	l/min	2 x 214
Pompa alim. morsa/perforazione <i>Oscillator/drilling control pump</i>	l/min	160
Pressione di taratura / Set pressure	MPa	30

* Conforme alle norme sulle emissioni dei diesel industriali / Nonroad diesel exhaust regulation compliance (EU - 97/68/CE, U.S.A. - EPA; California - CARB).

CIRC. INVERSA / RC REVERSE CIRCULATION

Profondità max. <i>Max depth.</i>	m	50
Diametro max. <i>Max diam.</i>	mm	2000
Tiro estrazione <i>Extracting force</i>	kN	360
Peso macchina <i>Machine weight</i>	t	70÷75

BATTIPALO VIBROTREVI DRIVEN CAST-IN-SITU PILE

Profondità max. <i>Max depth.</i>	m	16,5
Diametro max. <i>Max diam.</i>	mm	600
Tiro estrazione <i>Extracting force</i>	kN	732
Peso macchina <i>Machine weight</i>	t	70

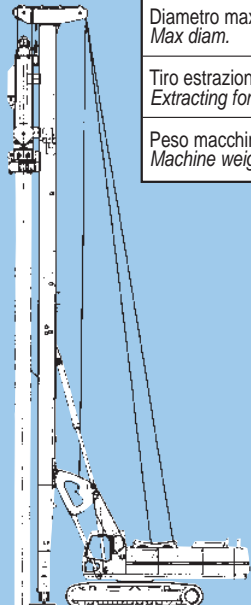

DIAFRAMMI con BH DIAPHRAGM WALL with BH

Profondità max. <i>Max depth.</i>	m	50
Sezione max. (scavo) <i>Max section (excavation)</i>	mm	3000 x 1000
Tiro estrazione <i>Extracting force</i>	kN	256
Peso macchina <i>Machine weight</i>	t	55÷70

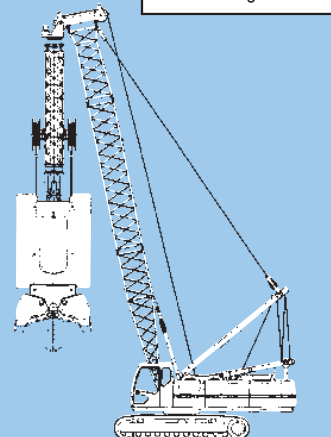

CARATTERISTICHE PRINCIPALI
MAIN FEATURES

- 1** Sottocarro con cingoli espandibili, sistema a parallelogrammo.
Undercarriage with expandable track, parallelogram system.
- 2** Zavorra auto-sollevante.
Self-lifting counter weight.
- 3** Torretta su ralla di rotazione a 360° con motore Deutz BF6M1015 o BF6M1015C insonorizzato e relativo impianto idraulico.
Hydraulic power pack powered by Deutz BF6M1015 or BF6M1015C diesel engine complete with soundproof canopy and mounted on the new heavy duty 360° slewing ring.
- 4** Gruppo argani.
Winch assembly.
- 5** Sistema a parallelogramma che permette di variare il raggio di lavoro mantenendo l'antenna sempre in posizione verticale.
The boom is mounted on a special parallelogram system, which allows the working radius to be varied whilst maintaining the mast in vertical position.
- 6** Antenna automontante sulla quale può essere applicata la coppia massima su tutta l'altezza. È composta da un elemento intermedio di 13.5 m, un elemento inferiore di 2.6 m ed una prolunga di 1.5 m.
Self erecting mast, which is designed so as to allow the max. torque value along its complete length. It is composed of 2.6 m long lower section, 13.5 m long intermediate element and 1.5 m top extension.
- 7** Testata.
Sheave cathead.
- 8** Sistema di spinta mediante cilindro idraulico con corsa di 6.5 m e due posizioni di fissaggio sul carrello della rotary per agevolare l'uso di una morsa giratubi.
Crowd cylinder 6.5 m stroke having two mounting positions on rotary cradle to facilitate the use of casing oscillator.
- 9** Testa di rotazione a 4 velocità di perforazione ed una velocità di scarico veloce. Per ciascuna velocità di perforazione si raggiunge la coppia massima.
Rotary head with 4 drilling speeds and an additional high spin off speed. For each drilling speed the max torque is available.
- 10** Asta telescopica con guida, disponibile in versione a bloccaggio meccanico o frizione.
Telescopic kelly complete with top guide mechanical locking or friction.
- 11** Predisposizione meccanica ed idraulica per morsa giracolonna.
Mechanical and hydraulic pre-arrangement for casing oscillator.

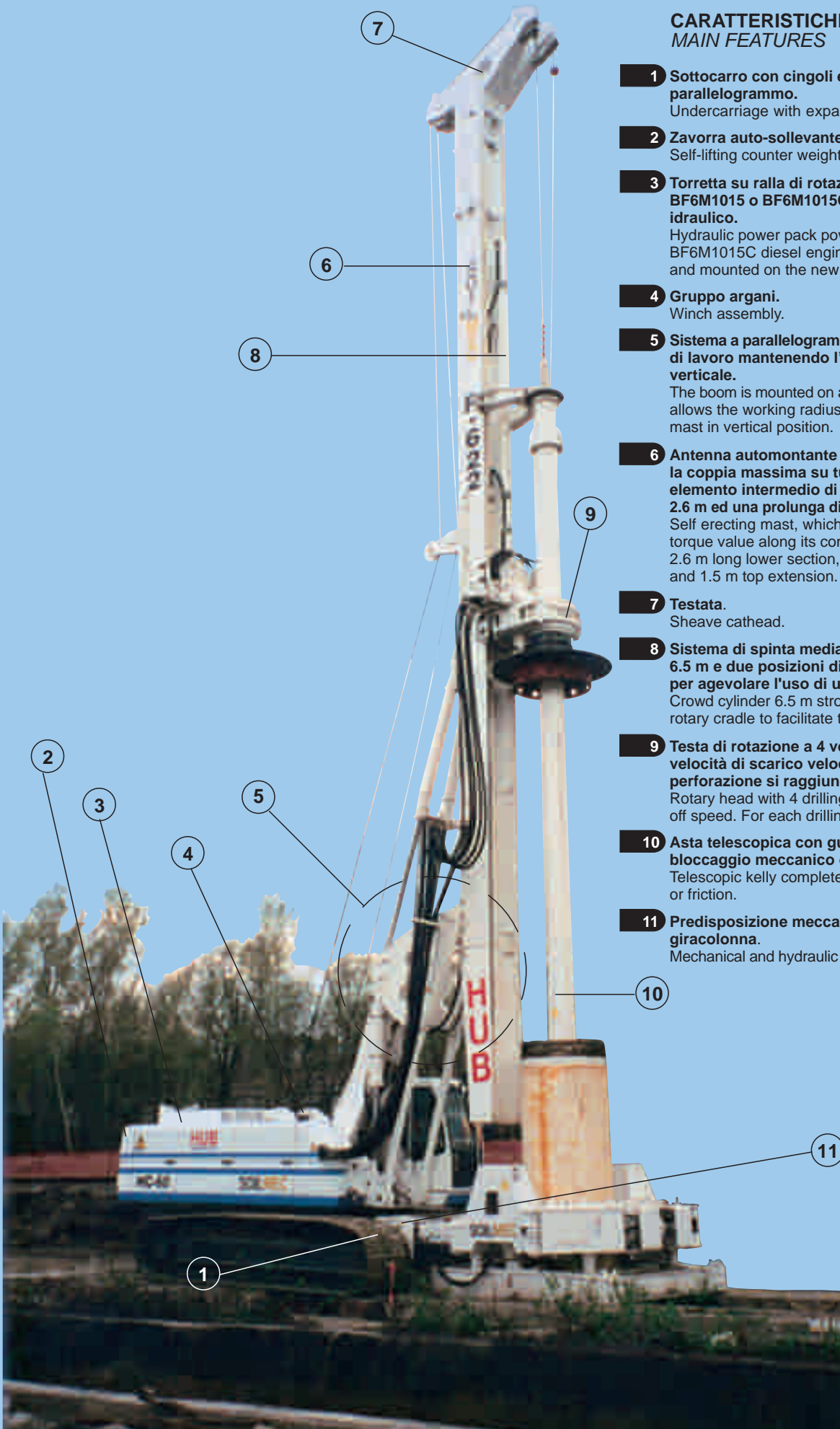

Rotary idrauliche Hydraulic rotary rigs

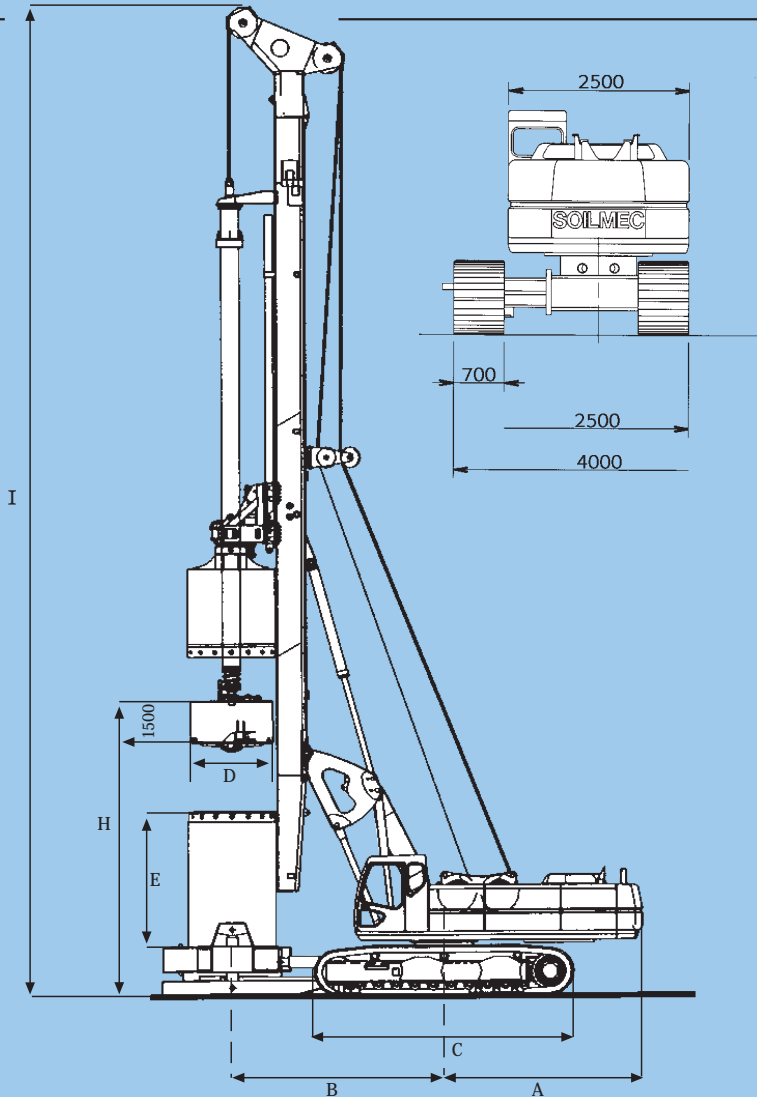

Sistema di Qualità Certificato
Certified Quality System

Dal 1990 la Soilmec si è uniformata alle normative previste dal sistema di Qualità ISO 9001/UNI 29001.

In 1990 Soilmec was awarded the certification of its own Quality System to ISO 9001/UNI 29001 series standards

A	Raggio di rotazione torretta <i>Tail/swing radius</i>	mm	4530
B	Asse di rotazione - asse di scavo <i>Radius of front end</i>	mm	4800
C	Lunghezza totale cingolo <i>track total length</i>	mm	5350
D	Diametro max con morsa <i>Max diameter with casing oscillator</i>	mm	2000
D	Diametro max.* <i>Max diameter *</i>	mm	2500
E	Altezza max tubo colonna <i>Max length of casing element</i>	mm	6000
H	Altezza attacco utensile, da terra <i>Tool connection height from ground level</i>	vedi tabella aste <i>see kelly table</i>	
I	Altezza totale macchina <i>Machine total height</i>	mm	22500

* si può ottenere smontando la parte inferiore del mast
may be obtained by removing the lower mast element

MACCHINA BASE BASIC CARRIER MODEL

Sottocarro tipo <i>Type of undercarriage</i>	Tipo <i>Type</i>	D7D a parallelogramma / parallelogram
Larghezza chiuso / aperto <i>Retracted / Extended width</i>	mm	2500 / 4000 (2900 / 4200)
Larghezza pattini <i>Shoes width</i>	mm	700 (900)
Passo <i>Centre idler to centre drive sprocket</i>	mm	4420
Zavorra <i>Counterweight</i>	kg	9000
Argano principale <i>Main winch</i>	Tipo <i>Type</i>	SW-200
Opzionale/Optionals		SF-200
Argano ausiliario <i>Auxiliary winch</i>	Tipo <i>Type</i>	SW-140
Opzionale/Optionals		SF-100 SF-140
Solo vers. diaframmi <i>Diaphragm wall equip. only</i>		SW-200 SF-200

SF = Argano a caduta libera / Free-Fall

SW = Argano a caduta controllata / Controlled descent

Cifre / Figures = kN nominali / Nominal kN

ASTE A FRIZIONE Ø 406 KELLY FRICTION Ø 406

n° elementi <i>n° elements</i>	lungh. <i>length</i>	profondità <i>depth</i>	peso <i>weight</i>	H
4x	10.5 m	37,0 m	5700 kg	9,2 m
4x	11.5 m	41,5 m	6200 kg	8,1 m
4x	13.5 m	49,6 m	7100 kg	6,0 m
4x	15.5 m	57,9 m	8000 kg	3,9 m
4x	16.5 m	62,0 m	8500 kg	2,9 m
5x	10.5 m	46,2 m	5500 kg	9,2 m
5x	11.5 m	51,6 m	6000 kg	8,1 m
5x	13.5 m	61,9 m	6900 kg	6,0 m
5x	15.5 m	72,2 m	7900 kg	3,9 m
5x	16.5 m	77,4 m	8400 kg	2,9 m

ASTE A BLOCCAGGIO MECCANICO Ø 406 KELLY MECHANICAL LOCKING Ø 406

4x	10.5 m	37,0 m	5800 kg	9,2 m
4x	11.5 m	41,1 m	6300 kg	8,1 m
4x	13.5 m	49,4 m	7200 kg	6,0 m
4x	15.5 m	57,8 m	8200 kg	3,9 m
4x	16.5 m	62,0 m	8700 kg	2,9 m

La misura standard per il quadro attacco utensili è 150 x 150
Standard dimension of tool connection is 150 x 150 mm

Tutti i dati tecnici riportati sono da considerare indicativi.
La SOILMEC si riserva la facoltà di modificarli opportunamente.
All technical data are purely indicative and subject to change without notice.



SOILMEC 

Drilling and Foundation Equipment
5819, via Dismano - 47023 Cesena (FC) - Italy
Tel. +39-0547-319111 Fax +39-0547-318548
<http://www.soilmec.it>
e-mail: soilmec@soilmec.it