

Hydraulic Rotary Rig

# SR-45



**soilmec**   
Drilling and Foundation Equipment

# SR-45 Hydraulic Rotary Rig

## LDP APPLICATIONS

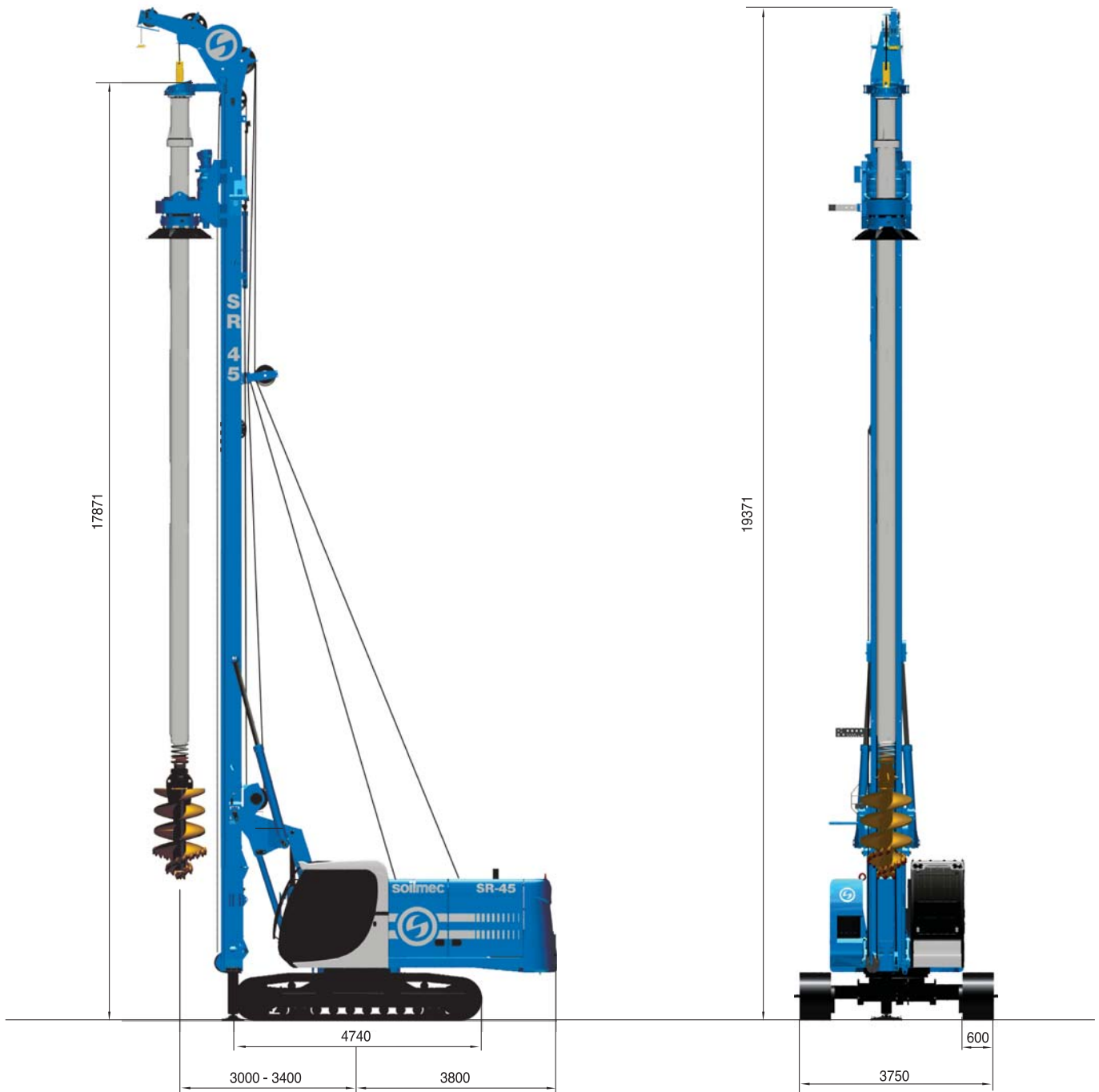

### LDP - Large Diameter Piles - WCS version

Operating weight c/w 4x9 kelly bar	42000 kg	92593 lb
Max pile diameter (along mast)	1300 mm	51.18 in
Max pile diameter w/o lower mast section, tool below mast	2000 mm	78.74 in
Max pile depth-friction kelly	63- 65,5* m	207- 215* ft
Max pile depth-locking kelly	49- 51,8* m	160-170* ft

\* c/w non self-mounting 4x14 kelly bar

# SR-45 Hydraulic Rotary Rig

## LDP APPLICATIONS

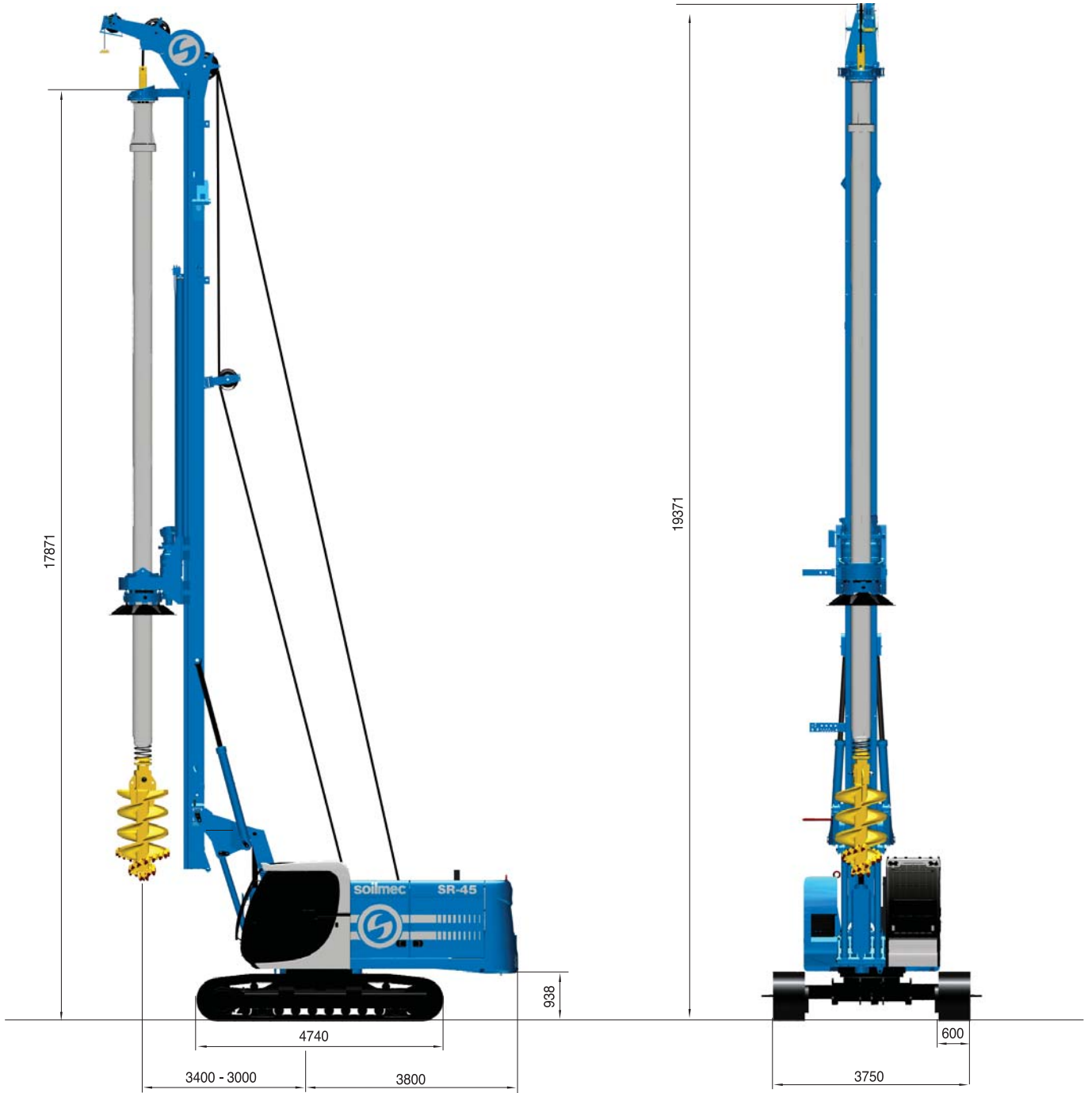

### LDP - Large Diameter Piles - CCS version

Operating weight c/w 4x9 kelly bar	40500 kg	89286 lb
Max pile diameter (along mast)	1500 mm	59.06 in
Max pile diameter tool below mast	2000 mm	78.74 in
Max pile depth-friction kelly (5x - 6x elements)	58,5 - 65* m	192 - 213* ft
Max pile depth-locking kelly	47,5 - 50,5* m	156 - 166* ft

\* c/w non self-mounting 4x14 kelly bar

# SR-45 Hydraulic Rotary Rig

## ROTARY TABLE

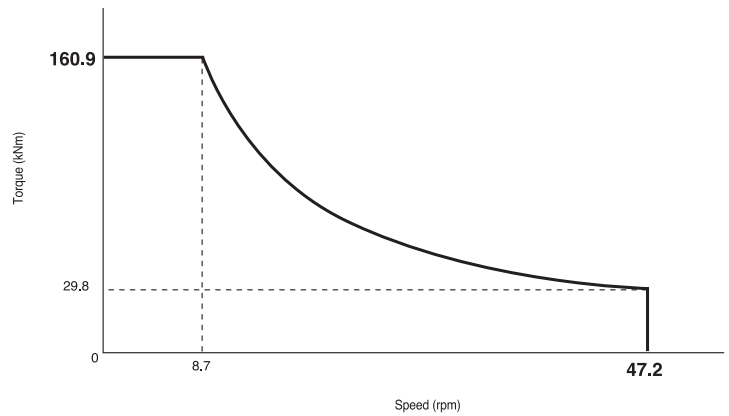
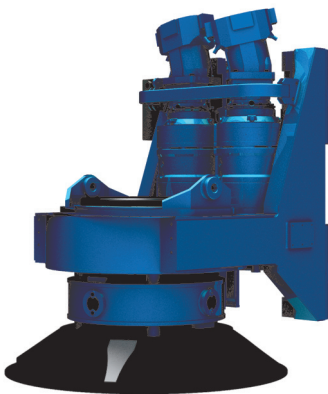
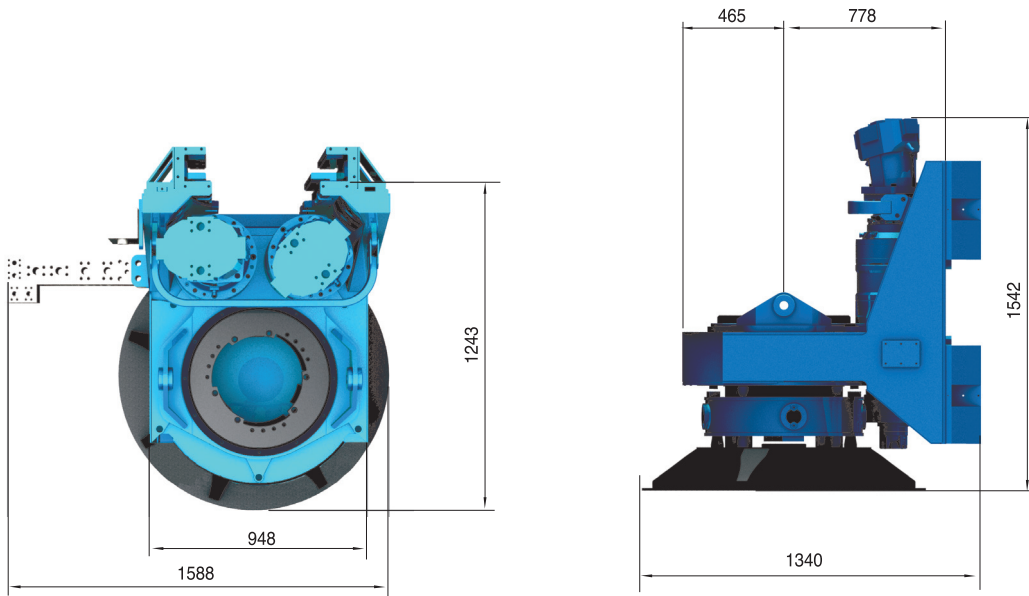

Rotary drive	Single gear version	Single gear version
- Max torque (theoretical-restricted-intermittent)	185 kNm	136447 lbf*ft
- Rated torque (theoretical)	161 kNm	118746 lbf*ft
- Speed of rotation (max)	47 rpm	47 rpm
- Spin-off speed	146 rpm	146 rpm
- Weight c/w cradle	2715 kg	5985 lb

# SR-45 Hydraulic Rotary Rig

## TECHNICAL DATA SHEET

<b>CCS - Crowd system</b>		
	<b>Cylinder</b>	<i>Cylinder</i>
- Crowd force pull (down/up)	140 / 207 kN	31500 / 46500 lbf
- Stroke	5100 mm	201 in
- Speed (down/up)	17,4 m/min	57 ft/min
- Fast speed (down/up)	18,8 m/min	62 ft/min
<b>WCS - Crowd system</b>		
	<b>Winch</b>	<i>Winch</i>
- Crowd force pull (down/up)	240 / 240 kN	54000 / 54000 lbf
- Stroke	14500 mm	740 in
- Speed (down/up)	28 m/min	92 ft/min
- Fast speed (down/up)	28 m/min	92 ft/min
<b>Main winch SW320</b>	<b>controlled descent</b>	<i>controlled descent</i>
- Line pull (1st layer)	165 kN	37100 lbf
- Rope diameter	24 mm	1.26 in/482.28 ft
- Line speed (max.)	78 m/min	256 ft/min
<b>Auxiliary winch SW130</b>	<b>controlled descent</b>	<i>controlled descent</i>
- Line pull (1st layer)	65 kN	29225 lbf
- Rope diameter	18 mm	0.87 in
- Line speed (max.)	81 m/min	230 ft/min
<b>Engine</b>	<b>CUMMINS QSB 6.7</b>	<i>CUMMINS QSB 6.7</i>
- Rated output ISO 3046-I	201 kW @ 2000 rpm	269 HP @ 2000 rpm
- Engine conforms to Exhaust emission Standard	EU stage III B, US EPA Tier 4i	EU stage III B, US EPA Tier 4i
- Diesel tank capacity	380 l	100 US gal
<b>Hydraulic system</b>		
- Hydraulic pressure set	30,5 Mpa	4420 psi
- Flow rates (main circuits)	2x 214 l/min	2x 57 US gal/min
- Hydraulic oil tank capacity	450 l	119 US gal
<b>Undercarriage</b>	<b>variable gauge, telescoping side frames</b>	<i>variable gauge, telescoping sides frames</i>
- Overall width of crawlers retracted/extended	2550 / 3750 mm	100 / 147 in
- Width of triple grouser track shoes	600 mm	24 in
- Overall length of crawlers	4740 mm	187 in
- Traction force effective/nominal	386 kN	68800 lbf
- Travel speed	2 km/h	1.2 mph
<b>Mast inclination (Backward/ Forward/Lateral)</b>	<b>5/4/3°</b>	<i>5/4/3°</i>

## STANDARD EQUIPMENT

- Main and auxiliary winch controlled descent type with special grooving
- Hoist limit switch on main rope
- Swivel for main rope
- Service rope parking point
- DMS system electronic monitoring and operator interface system
- Mast inclination measurement on X/Y axes (digital/analog display)
- Automatic vertical mast alignment
- Depth measuring device on main winch
- Speed measuring device on rotary
- Crowd pressure setting
- Oscillator attachment brackets
- Central lubrication system
- Emergency mode of operation for engine
- Engine diagnostic system
- Diagnostic panel for hydraulic functions
- Transport securing lugs on crawler units
- On board lighting set
- On board tool set
- Electric refuelling pump
- High comfort operator's cab
- Protective roof grate (FOPS compliant)
- Air conditioning system
- Radio and CD player
- Videocamera set

## OPTIONAL EQUIPMENT

- Biodegradable oils
- Pressurized air conditioning system
- Freefall auxiliary winch
- Swivel for auxiliary rope
- Double roller auger cleaner
- VTH-1 vibrator
- Main winch load cell
- Additional counterweight for mast lattice boom extension application

# SR-45 Hydraulic Rotary Rig

## KELLY DRILLING SYSTEM

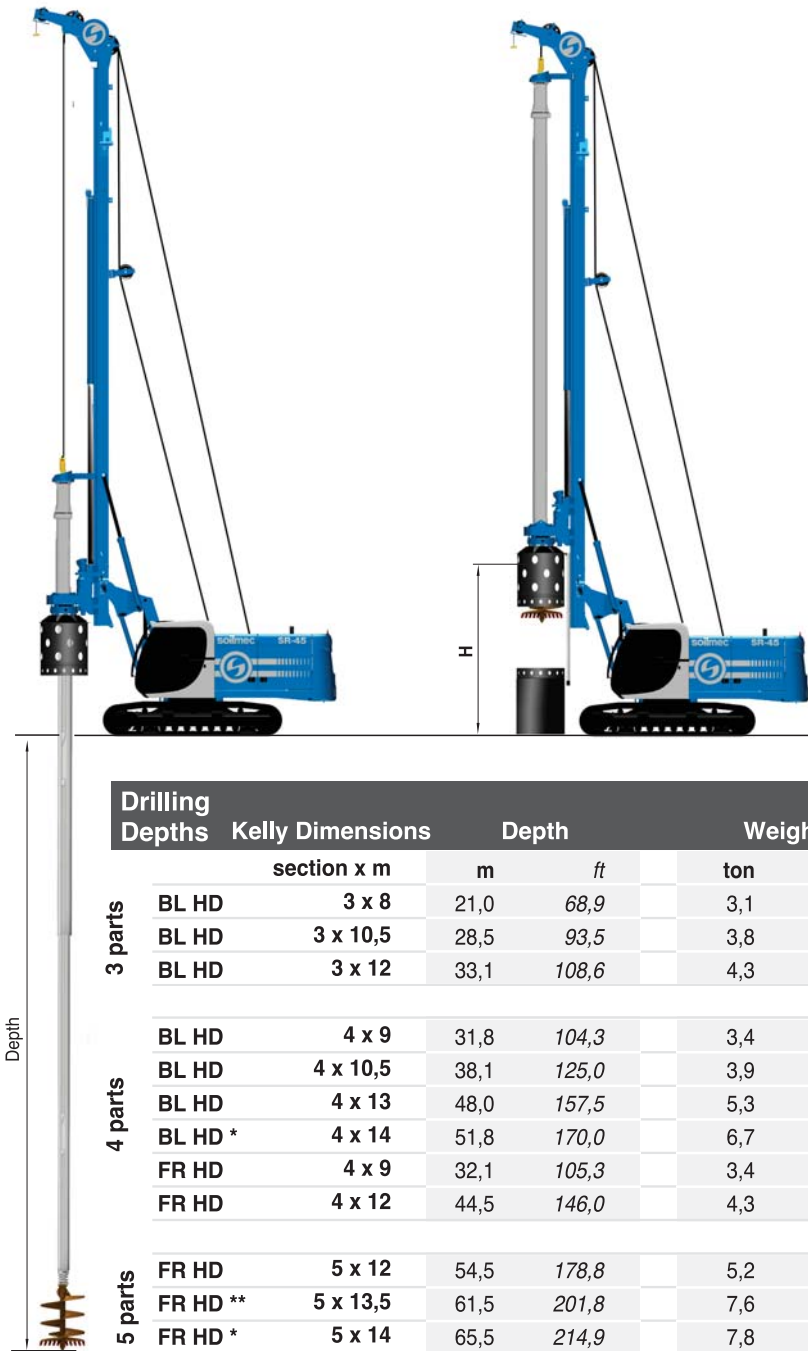

Drilling Depths	Kelly Dimensions section x m	Depth		Weight		CCS SYSTEM		WCS SYSTEM	
		m	ft	ton	ton	H		H	
						m	ft	m	ft
3 parts	BL HD 3 x 8	21,0	68,9	3,1	3.1	7,9	25.9	8,8	28.9
	BL HD 3 x 10,5	28,5	93,5	3,8	3.9	6,3	20.7	6,3	20.7
	BL HD 3 x 12	33,1	108,6	4,3	4.4	4,8	15.7	4,8	15.7
4 parts	BL HD 4 x 9	31,8	104,3	3,4	3.5	7,8	25.6	7,8	25.6
	BL HD 4 x 10,5	38,1	125,0	3,9	4.0	6,3	20.7	6,3	20.7
	BL HD 4 x 13	48,0	157,5	5,3	5.4	3,9	12.8	3,9	12.8
	BL HD * 4 x 14	51,8	170,0	6,7	6.8	2,9	9.5	2,9	9.5
	FR HD 4 x 9	32,1	105,3	3,4	3.5	7,9	25.9	7,9	25.9
	FR HD 4 x 12	44,5	146,0	4,3	4.4	5,0	16.4	5,0	16.4
5 parts	FR HD 5 x 12	54,5	178,8	5,2	5.3	4,9	16.1	4,9	16.1
	FR HD ** 5 x 13,5	61,5	201,8	7,6	7.7	5,5	18	5,5	18
	FR HD * 5 x 14	65,5	214,9	7,8	7.9	3,0	9.8	3,0	9.8

\* Non self-mountable kelly bar

\*\* Rathole dedicated kelly bar

# SR-45 Hydraulic Rotary Rig

## LDP APPLICATIONS - Ratholders version

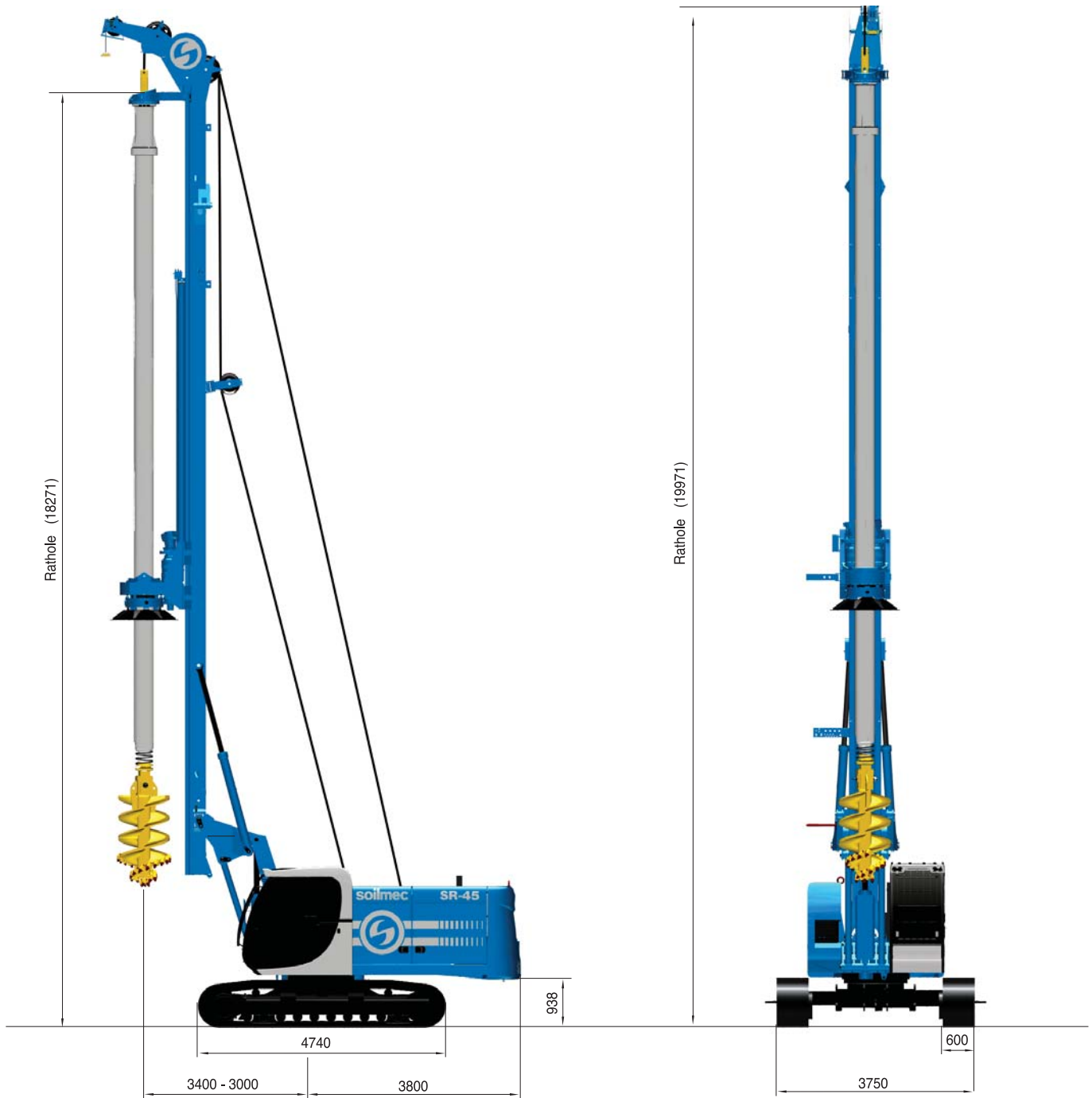

### LDP\_Large Diameter Piles - CCS Ratholders version

Operating weight c/w 5x13,5 kelly bar	42000 kg	92593 lb
Max pile diameter (along mast)	1300 mm	51.18 in
Max pile diameter w/o lower mast section, tool below mast	2000 mm	78.74 in
Max pile depth - locking kelly (reduct torque)	61,5 m	201.77 ft

# SR-45 Hydraulic Rotary Rig

CFA APPLICATIONS      Quick conversion kit



CFA - Continuous Flight Auger - Quick conversion kit		
Max pile diameter	900 mm	35.43 in
Max pile depth c/w 7 m auger extension	21 m	68.90 ft
Max pile depth with auger cleaner c/w 7 m auger extension	20 m	65.62 ft
Extraction force	394 kN	88571 lbf
Crowd force on auger	138 kN	31022 lbf



# SR-45 Hydraulic Rotary Rig

CFA APPLICATIONS 4° line pull



## CFA - Continuous Flight Auger - 4° linepull

Max pile diameter	900 mm	35.43 in
Max pile depth c/w 6 m auger extension	21,5 m	70.54 ft
Max pile depth with auger cleaner c/w 6 m auger extension	20,5 m	67.26 ft
Extraction force	480 kN	107904 lbf
Crowd force on auger (opt.)	100 kN	22480 lbf

# SR-45 Hydraulic Rotary Rig

DP APPLICATIONS Quick conversion kit

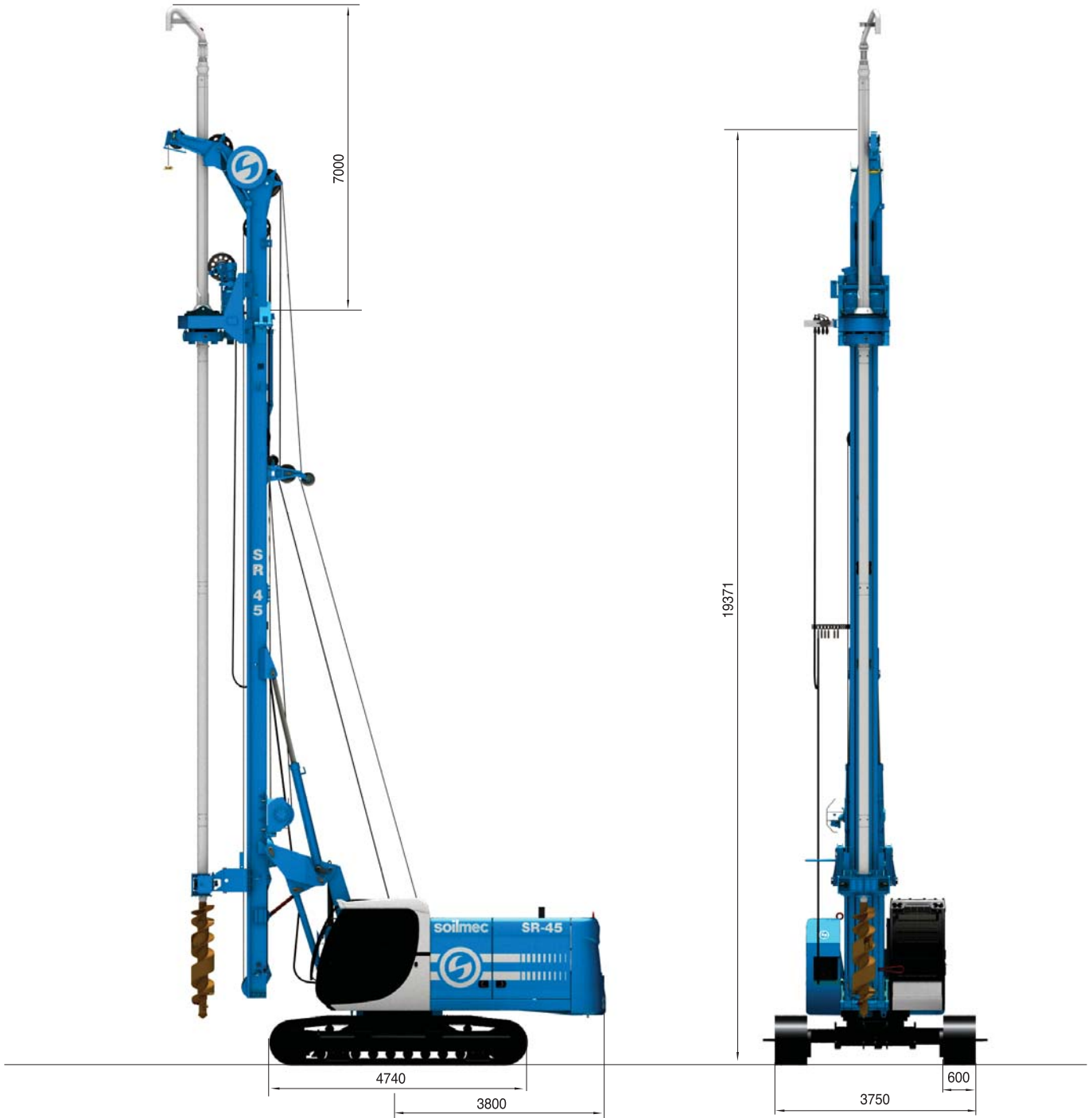

DP - Displacement Piles - Quick conversion kit		
Max DP pile diameter	350 mm	14 in
Max TCT pile diameter	350 mm	14 in
Max pile depth c/w 7 m auger extension	19,7 m	64.63 ft
Mast lattice boom extension length	12 m	39.37 ft
Max depth c/w lattice boom mast extension	23 m	74.47 ft

# SR-45 Hydraulic Rotary Rig

TJ APPLICATIONS Quick conversion kit



## TJ - Turbojet® - Quick conversion kit

Max treatment diameter	900 mm	35.43 in
Max pile depth c/w 7 m auger extension	20,4 m	66.93 ft
Max lattice boom extension length	12 m	39.37 ft
Max depth c/w lattice boom mast extension	23 m	76.77 ft

# SR-45 Hydraulic Rotary Rig

## TRANSPORT, DIMENSIONS AND WEIGHTS

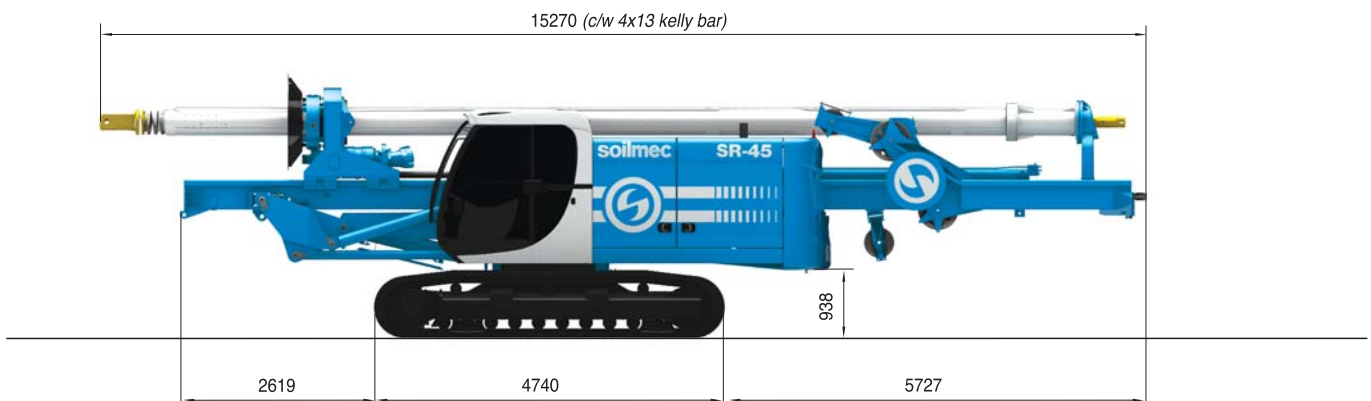
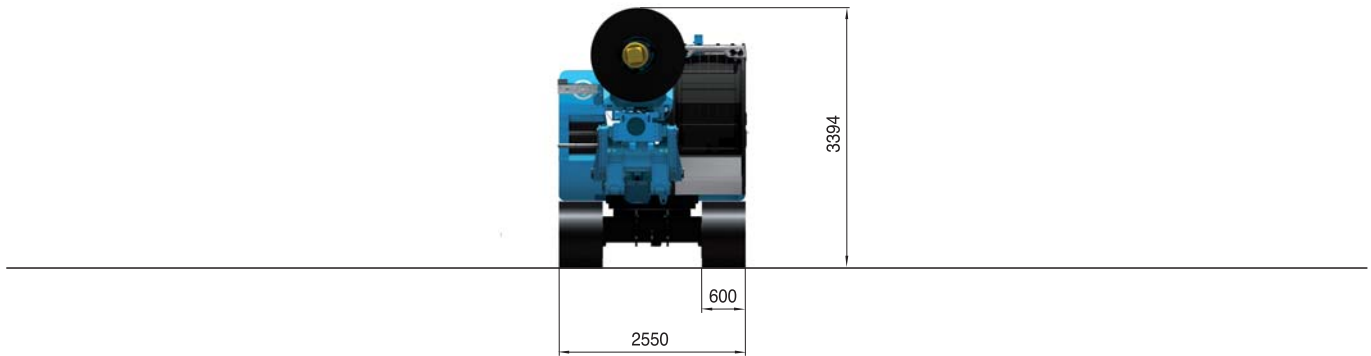

Transport configuration		
Transport width	2550 mm	100 in
Transport height	3400 mm	134 in
Transport length (w/o mast)	13050 mm	514 in
CCS Version - Transport weight c/w 4x9 kelly bar	40500 kg	89286 lb
WCS Version - Transport weight c/w 4x9 kelly bar	42000 kg	92593 lb

This brochure has been edited and distributed by SOILMEC Spa. The present document cancels and override any previous ones. This brochure shall not be distributed, reproduced or exhibited without SOILMEC Spa. authorization in accordance with to SOILMEC web site disclaimer condition.

SOILMEC Spa distributes machinery and structures all over the world, supported by SOILMEC Spa subsidiary companies and dealers. The complete Soilmec network list is available on the web site [www.soilmec.it](http://www.soilmec.it)